

JIS10K

ANSI/ASTM

DIN/ISO

ESLON DIAPHRAGM VALVE



- Excellent sealing performed with optimized diaphragm design even by low handle operating torque.
- Improved diaphragm in compression set steadily prevents leakage.
- Available customized version for the applications in high temperature.
- Visual indicator at the handle top for open-close position and prevention of over tightening.
- Drip-proof and dust-proof mechanism for prevention of entering water and dust in bonnet.
- Flat at the bottom of flange and insert nuts for prevention of tumbling and for better workability in plumbing.

Flange Type

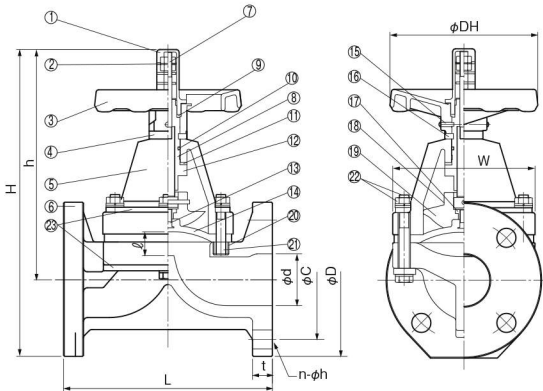

Parts List

No.	Part Name	Q'ty	Material	No.	Part Name	Q'ty	Material
①	Indicator Cover	1	PC	⑭	Diaphragm	1	EPDM, PTFE, PTFE+C-PE
②	Indicator	1	SUS304	⑮	Lock Pin for 32~250A	2	SUS304
③	Handle	1	ABS	⑯	Stem Set	1	PP or PVC
④	Collar	1	PE	⑰	Metallic Fixtures for Compressor	1	C3604 or Ti-Pd
⑤	Bonnet	1	PVC, HT, PP, GFPP, PVDF	⑱	Lock Pin for Compressor	1	SUS304 or Ti-Pd
⑥	Body	1	PVC, HT, PP or PVDF	⑲	Compressor	1	15~150A GF-PP 200, 250A FCD
⑦	Indicator Stud Bolt	1	SUS304	⑳	Insert Nut	-	C3604, SUS304
⑧	Stem Sleeve	1	C3604	㉑	Stud Bolt	-	SUS304
⑨	Stem Packing	1	NBR	㉒	Bolt & Nut	-	SUS304
⑩	O-ring	1	NBR	㉓	Reinforcement Plate for HT, PP, PVDF	1	SUS304 or SS400 Painted by Epoxy Resin
⑪	Thrust Washer	1	PTFE, SUJ				
⑫	Stem Spindle	1	C3604				
⑬	Insert Bolt	EPDM 1 PTFE 1	Cr Plated SS SUS304 or Ti-Pd				

- Quantity of ㉑-㉒ bolts & nuts differ depending on size of valve.
- Lock pin for handle is not attached for the sizes up to 25A.
- Reinforcement plate is attached to HT, PP, and PVDF type.

Size

Size		d	L	H	h	DH	W	ℓ	Flange (JIS 10K)				Weight (kg/pc)				Q'ty per Carton
A	B								φD	φC	n-φh	t	PVC	HT	PP	PVDF	
15	1/2	16	110	166	119	80	76	10	95	70	4-15	14	0.9	1.1	0.8	1.1	8
20	3/4	20	120	180	130	80	82	12	100	75	4-15	14	1.0	1.3	1.0	1.3	8
25	1	25	130	195	133	80	90	15	125	90	4-19	14	1.4	1.7	1.3	1.7	8
32	1 1/4	41	180	269	199	125	122	20	140	100	4-19	16	2.6	3.3	2.5	3.4	2
40	1 1/2	41	180	269	199	125	122	20	140	105	4-19	16	2.6	3.3	2.5	3.4	2
50	2	52	210	308	230	148	142	27	155	120	4-19	20	3.6	4.5	3.4	4.8	2
65	2 1/2	67	250	379	291	210	170	36	175	140	4-19	22	6.2	7.7	5.9	8.4	2
80	3	80	280	415	322	210	202	37	185	150	8-19	22	8.2	9.6	7.9	11.2	2
100	4	100	340	497	392	260	255	61	210	175	8-19	24	13.8	18.3	15.4	21.1	1
125	5	125	410	560	435	350	320	61	250	210	8-23	24	21.8	-	20.0	26.0	1
150	6	150	480	630	490	350	375	70	280	240	8-23	26	26.3	-	25.5	36.0	1
200	8	198	570	790	632	410	416	96	330	290	12-23	29	51.0	-	44.0	61.0	1
250	10	248	680	980	780	555	540	132	400	355	12-25	31	93.0	-	77.0	108.0	1

- Bolt hole dimensions on flange conform to JIS B2220.
- Flange dimension of 32A is same as 40A, but long bolt hole on the flange.

Usable Liquid Temperature & Maximum Working Pressure

Material	Usable Temperature (°C)	max. Working Pressure at Room Temp (MPa)							
		EPDM				PTFE			
		15~100A	125-150A	200A	250A	15~100A	125A	150A	200-250A
PVC	0~60	1.0	0.8	0.5	0.45	1.0	0.7	0.5	0.4
HT	0~90	1.0	-	-	-	1.0	-	-	-
PP	0~90	1.0	0.8	0.5	0.45	1.0	0.7	0.5	0.4
PVDF	0~120	1.0	0.8	0.5	0.45	1.0	0.7	0.5	0.4

Conforming Standard

Connection	Standard	Classification
Flange	JIS10K	JIS B 2220
	ANSI	ANSI B16.5
	DIN/ISO	DIN2501 (ISO7005 PN10)
Socket	JIS10K	JIS K 6743
	ASTM	ASTM D2467
Thread	DIN/ISO	DIN2501 PN10/PN16 (ISO7005 PN10)
	JIS10K	JIS B 0203
Butt	ANSI	ANSI B1.20.1
	DIN/ISO	DIN2501 PN10/PN16 (ISO7005 PN10)
	DIN/ISO	DIN8077 (PP) ISO10931 (PVDF)

*For flange, dimension of bolt holes conforming the standards