

True Union Ball Valve

ADVANTAGES:

- 1) Materials meet drinking water standard
- 2) Smooth opening & closing thanks to a lower torque
- 3) 100% pure virgin material, CaCO3 free (Chalk)
- 4) UV resistant powder added
- 5) 100% pressure testing before leaving the factory
- 6) Can be assembled with Pneumatic/Electric Actuators

DESCRIPTION:

- 1) Material: UPVC, CPVC, PP, PVDF
- 2) Size: 1/2" - 4"; 20mm - 110mm; DN15 - DN100
- 3) Standard: ANSI, DIN, JIS, CNS
- 4) Joint End: Socket, Threaded(NPT, PT, BSPF), Fusion, Welding
- 5) Seat - PTFE; ORING - EPDM, VITON/FKM
- 6) Working Pressure: 150 PSI
- 7) Operating Temperature: UPVC(0~55°C); CPVC & PP(0~95°C)
- 8) Handle color : red, blue, green, black, yellow, purple
Valve body color : UPVC(dark gray), CPVC(light gray),
PP(light yellow), PVDF(ivory)



SPECIFICATIONS:

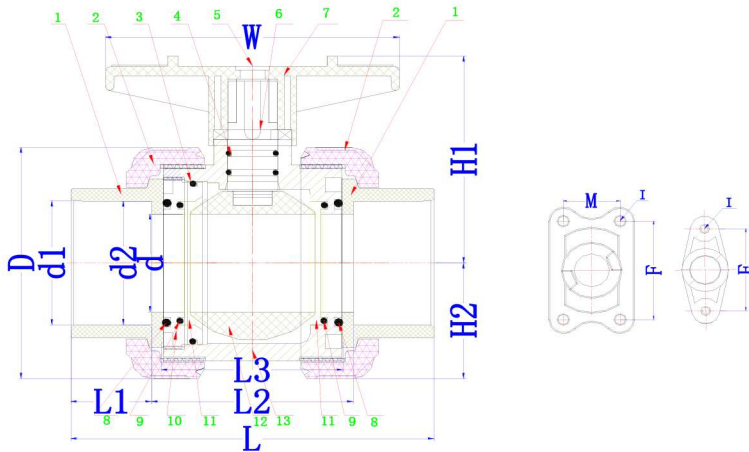

ITEM	PART	MATERIAL	QTY
3/ 4/ 8/ 9	ORING	EPDM / VITON	7
1	UNION END	UPVC / CPVC / PPH	2
2	UNION NUT	UPVC / CPVC / PPH	2
5	CAP	ABS	1
6	STEM	UPVC / CPVC / PPH	1
7	HANDLE	ABS	1
10	SEAL CARRIER	UPVC / CPVC / PPH	1
11	SEAT	PTFE	2
12	BALL	UPVC / CPVC / PPH	1
13	BODY	UPVC / CPVC / PPH	1

UNIT: MM

SIZE	d	d1					d2				
		ANSI	DIN	JIS	CNS	PPH	ANSI	DIN	JIS	CNS	PPH
1/2"(15)	15	21.40	20.25	22.30	22.40	19.30	21.25	20.05	21.85	21.90	19.00
3/4"(20)	20	26.75	25.25	26.30	26.40	24.10	26.58	25.05	25.85	25.90	23.80
1"(25)	25	33.52	32.25	32.33	34.50	31.00	33.28	32.05	31.85	33.90	30.70
1 1/4"(32)	32	42.28	40.25	38.43	42.50	39.00	42.05	40.05	37.85	41.90	38.60
1 1/2"(40)	40	48.40	50.25	48.46	48.60	49.00	48.12	50.05	47.75	47.90	48.60
2"(50)	50	60.45	63.25	60.56	60.60	61.90	60.18	63.05	59.75	59.90	61.40
2 1/2"(65)	63	73.30	75.25	76.60	76.70	73.60	72.85	75.05	75.87	75.90	72.30
3"(80)	75	89.25	90.35	89.60	89.70	88.30	88.70	90.05	88.83	88.90	86.90
4"(100)	90	114.60	110.35	114.70	115.00	108.00	114.10	110.05	113.98	113.80	106.40

SIZE	D	L	L1	L2	L3	W	H1	H2	F	M	I	operating torque (Nm)
1/2"(15)	54.00	108.00	23.00	62.00	52.00	84.00	52.50	27.50	31.00	-	M6	2.0
3/4"(20)	63.00	115.00	26.00	63.00	54.00	90.00	59.00	32.00	33.00	-	M6	2.5
1"(25)	73.50	130.00	29.00	72.00	62.00	106.00	67.50	37.25	40.00	-	M6	4.0
1 1/4"(32)	84.50	145.50	33.00	79.50	70.00	116.00	77.50	42.75	52.00	-	M8	5.0
1 1/2"(40)	98.00	161.00	35.50	90.00	79.50	128.00	90.00	50.00	52.00	-	M8	7.5
2"(50)	118.00	175.00	38.50	98.00	85.00	140.00	106.00	60.00	70.00	-	M8	8.5
2 1/2"(65)	150.00	276.00	64.50	147.00	133.00	198.00	136.50	76.50	84.00	45.00	M10	13.0
3"(80)	169.00	303.00	70.00	163.00	146.00	218.00	150.00	86.00	84.00	45.00	M10	16.0
4"(100)	190.00	353.00	84.00	185.00	160.00	235.00	166.00	98.00	121.00	49.00	M12	25.0

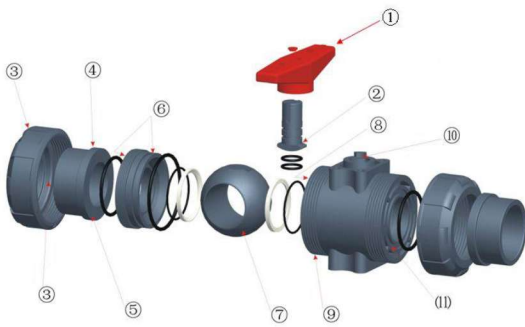

- ① Underside handle extends the length so that both OFF block will not be exposed, more beautiful
- ② Extrusive circular plane change to both side plane, easy processing and assemble
- ③ Lateral plane and ribs of the Union Cap, from the right-angle change to incline to increase the intensity
- ④ Union end from right-angle to slope increase in a round protruding rib to increase the intensity
- ⑤ Surface of Oring change to a plane, and each have been cutting lathe in order to ensure its flatness
- ⑥ Seal carrier and Oring slot is processed by machine, sealing performance is improved.
- ⑦ Each ball has increased turning and grinding to ensure that its true roundness and smoothness. So much easier to handle and not easy leak
- ⑧ Inside body is processed via CNC machine to make sure accurate dimensions
- ⑨ Increase the slope of trapezoidal teeth and the number of teeth in order to ensure their connection strength
- ⑩ Through hole is processed via CNC machine to make sure the stability of sealing
- ⑪ Slot dimension is improved, sealing performance is strengthened.

DISASSEMBLY DETAILS:

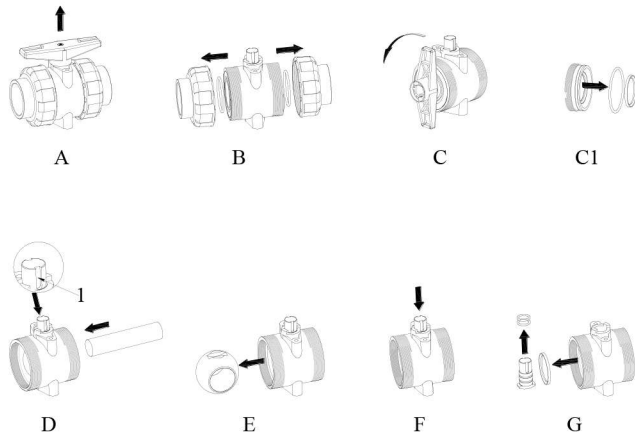

- A - pull out the handle
- B - take apart the nuts
- C - turn the seal carrier in an anticlockwise direction
- C1 - take out the Seat & Oring
- D - push the ball
- E - pick out the ball
- F - press the shaft
- G - pick out the Seat & Oring

Note:

- 1) For above "D" step, pls take note the groove position "1" on the shaft
- 2) To assemble the valve, pls follow up the steps from "G" to "A"

MATERIAL GUIDELINE FOR PRESSURE & TEMPERATURE:

PP, CPVC, UPVC Operating Temperature - Pressure

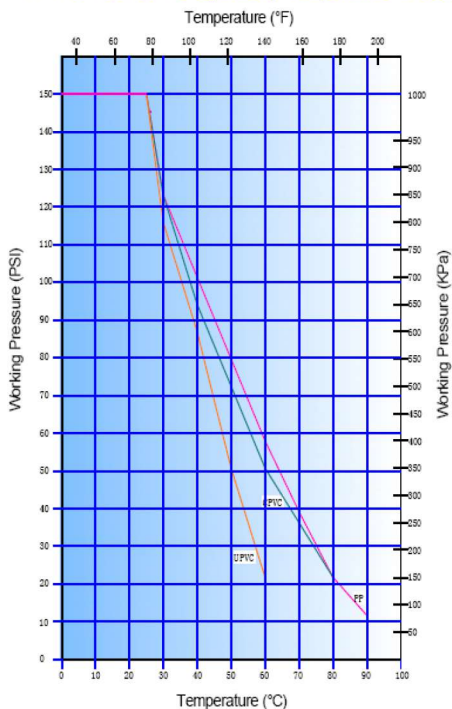

PVDF Operating Temperature - Pressure

