

JIS10K

ANSI/ASTM

DIN/ISO

ESLON BALL VALVE



- Left hand screw on ball stopper prevents screw loose and ensures sealing of body part when union nut is loosened.
- Full port in all size. No pressure loss at full opened position by nominal size of inner diameter.
- Keep water quality by little obstructed design in flow path.
- Six colors of handle for sizes 15~50A enable easier management of application and fluid classification.

6 Colors Handle for Easy Mentenance



Flange Type · Thread Type · TS Socket Type and Butt Spigot Type

● Flange Type

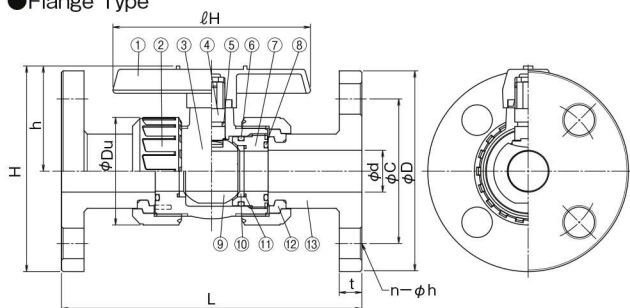

■ Parts List

No.	Part Name	Q'ty	Material	No.	Part Name	Q'ty	Material
①	Handle	1	ABS	⑨	Ball	1	PVC, HT, PP or PVDF
②	Union Nut	2	PVC, HT, PP or PVDF	⑩	Ball Seat	2	PTFE
③	Body	1	PVC, HT, PP or PVDF	⑪	Ball Seat O-Ring	2	EPDM or FKM
④	Stem	1	PVC, HT, PP or PVDF	⑫	Set Ring	2	PVC, HT, PP or PVDF
⑤	Stem O-Ring	—	EPDM or FKM	⑬	Flange	2	PVC, HT, PP or PVDF
⑥	Ball Holder O-Ring	—	EPDM or FKM	⑭	Thread	2	PVC or PVDF
⑦	Ball Holder	—	PVC, HT, PP or PVDF	⑮	Socket	2	PVC or HT
⑧	Union O-Ring	2	EPDM or FKM	⑯	Socket	2	PVDF

1.Quantity of ⑤ : 1 for 15~32A, 2 for 40~100A. 2.Quantity of ⑥, ⑦ : 1 for 15~50A, 2 for 65~100A.

⚠ Important Notes

- Gasifying, volatile, or evaporating fluid such as hydrogen peroxide and sodium hypochlorite might rise inner pressure of valve and burst the valve. Please contact us concerning such risk. Gas relief type of customized ball valve which has relief orifice on the ball is available.

■ Usable Liquid Temperature & Maximum Working Pressure

Material	Usable Temperature (°C)	max. Working Pressure at Room Temp (MPa)	Material	Usable Temperature (°C)	max. Working Pressure at Room Temp (MPa)
PVC	0~50	1.0	PP	-20~80	1.0
HT	0~90	1.0	PVDF	-20~100	1.0

● Female Thread Type

● TS Socket Type

● Butt Spigot Type

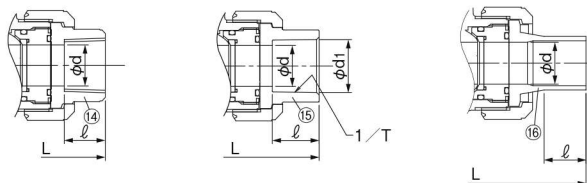

■ Flange Type

Size		d	L	H	h	ℓH	Du	Flange (JIS 10K)				Weight (kg/pc)				Q'ty per Carton
A	B							φD	φC	n-φh	t	PVC	HT	PP	PVDF	
15	1/2	15	143	98	50	95	49	95	70	4-15	14	0.4	0.4	0.3	0.5	12
20	3/4	20	172	103	53	95	59	100	75	4-15	14	0.6	0.6	0.4	0.7	12
25	1	25	187	129	66	123	67	125	90	4-19	14	0.9	0.9	0.5	1.0	12
32	1 1/4	30	190	142	74	123	81	135	100	4-19	16	1.2	1.2	0.7	1.3	12
40	1 1/2	40	212	170	100	152	98	140	105	4-19	16	1.7	1.7	1.1	1.9	2
50	2	50	234	185	107	152	120	155	120	4-19	20	2.6	2.6	1.6	3.0	2
65	2 1/2	65	259	222	146	188	150	175	140	4-19	22	4.2	4.3	2.8	5.0	2
80	3	80	304	262	169	230	186	185	150	8-19	22	6.7	6.9	4.4	8.2	2
100	4	100	372	317	203	283	228	210	175	8-19	24	11.5	11.9	7.4	14.1	1

■ Conforming Standard

Connection	Standard	Classification
Flange	JIS10K	JIS B 2220
	ANSI	ANSI B16.5
	DIN/ISO	DIN2501 (ISO7005 PN10)
Socket	JIS10K	JIS K 6743
	ASTM	ASTM D2467
Thread	JIS10K	JIS B 0203
	ANSI	ANSI B1.20.1
	DIN/ISO	DIN2501 PN10/PN16 (ISO7005 PN10)
Butt	DIN/ISO	DIN8077 (PP)
		ISO10931 (PVDF)

*For flange, dimension of bolt holes conforming the standards

Thread Type · TS Socket Type and Butt Spigot Type

Size		d	L				H	h	ℓH	Du	Female Thread		TS Socket		Butt Spigot	Weight (kg/pc)			Q'ty per Carton	
A	B		Thread	TS	PVDF						Size	Size	d1	1/T	ℓ	ℓ	PVC	HT		PVDF
				Thread	Butt					PVC	PVDF				Thread/TS Socket	TS	Thread/Butt			
15	1/2	15	97	109	99	143	75	50	95	Rc 1/2	18	20	22.3	1/37	22	30	0.2	0.2	0.2	24
20	3/4	20	117	132	116	152	82	53	95	Rc 3/4	18	22	26.3	1/42	25	24	0.3	0.3	0.3	24
25	1	25	128	143	136	161	100	66	123	Rc 1	23	24	32.3	1/43	29	24	0.4	0.4	0.5	24
32	1 1/4	32	146	166	148	167	115	74	123	Rc 1 1/4	23	25	38.4	1/37	32	25	0.6	0.6	0.6	24
40	1 1/2	40	163	175	169	190	149	100	152	Rc 1 1/2	25	28	48.5	1/38	35	24	1.1	1.1	1.2	4
50	2	50	188	203	196	216	167	107	152	Rc 2	30	30	60.6	1/34	38	28	1.6	1.7	1.9	4
65	2 1/2	65	227	259	227	208	221	146	188	Rc 2 1/2	32	32	76.6	1/48	61	23	3.0	3.3	3.6	2
80	3	80	278	311	278	301	262	169	230	Rc 3	37	37	89.6	1/49	64	45	5.6	6.1	7.0	1
100	4	100	330	390	330	340	317	203	283	Rc 4	45	45	114.7	1/56	84	43	10.5	11.2	12.5	1

*H, h, Du, and t dimension of PP/PVDF type might differ from the dimension table.

Ball Valve

Body material: **PVC**

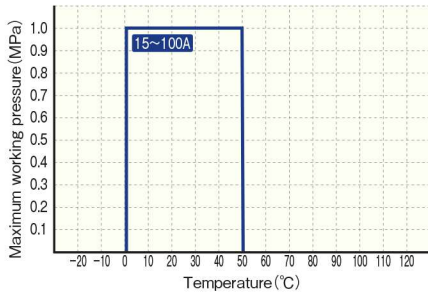

Body material: **HT**

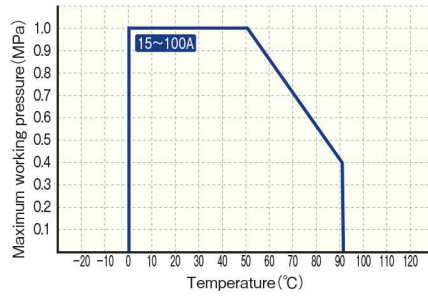

Body material: **PP**

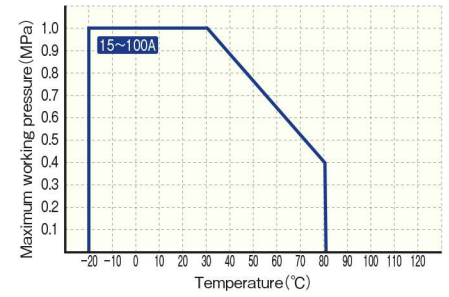

Ball Valve

Body material: **PVDF**

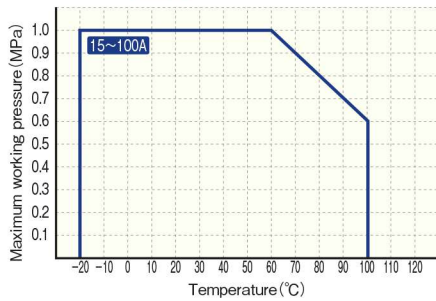

YP Ball Valve

Body material: **PVC**

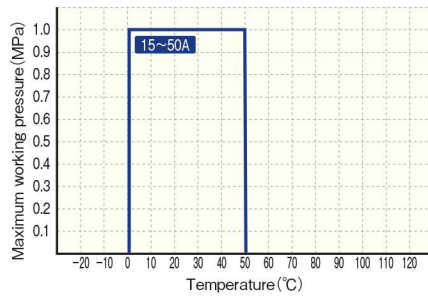

Lock Ball Valve•Compact Ball Valve

Body material: **PVC**

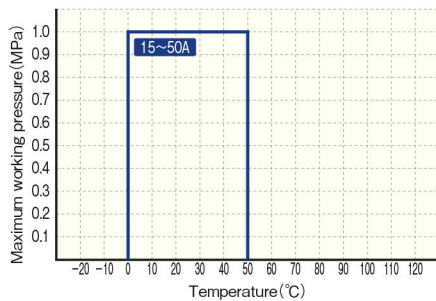

Mini Ball Valve

Body material: **PVC**

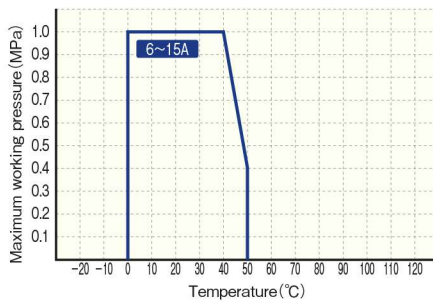

Butterfly Valve(Lever Type•Gear Type•For Under Ground)

Body material: **PVC**

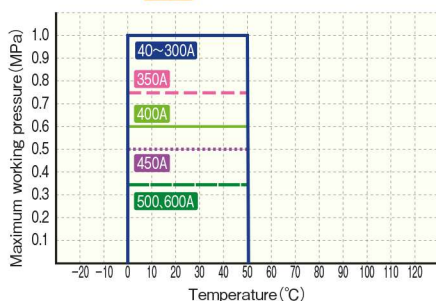

Body material: **PP**

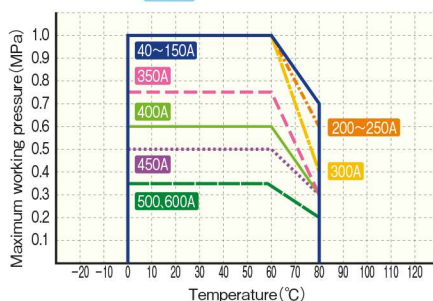

Body material: **PVDF**

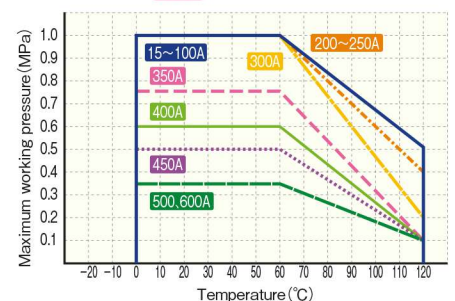

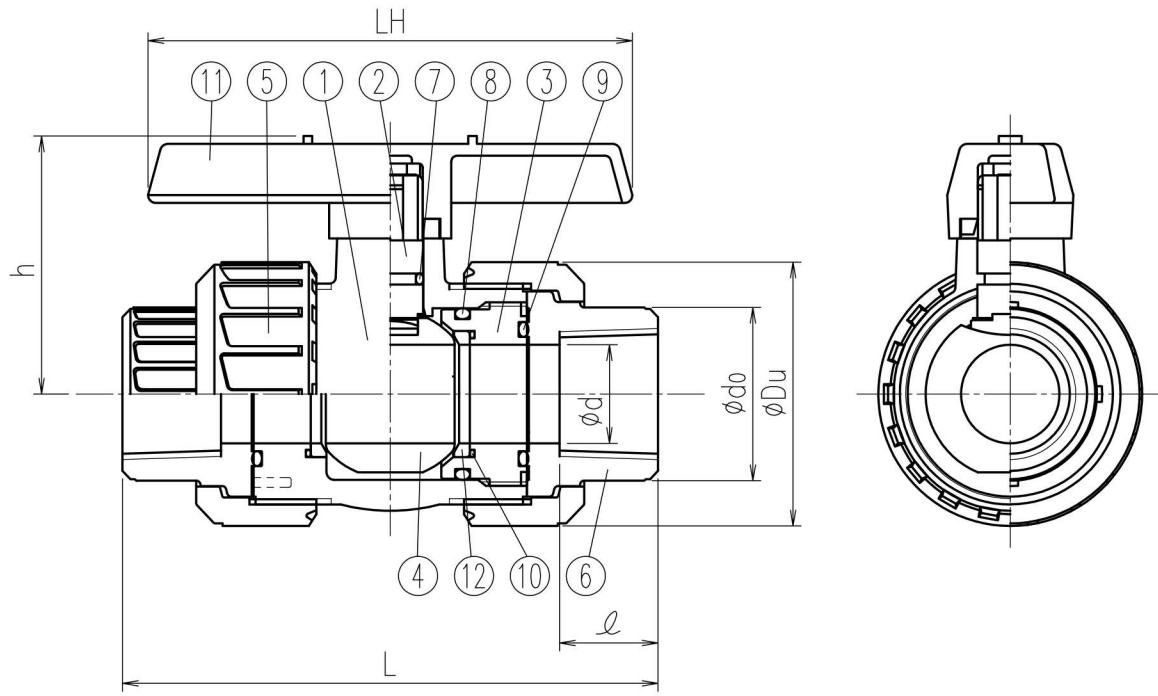

No.	Part Name	Q'TY	Material/Type
1	Body	1	
2	Stem	1	
3	Ball Holder	1	<input type="checkbox"/> PVC
4	Ball	1	<input type="checkbox"/> PVDF
5	Union Nut	2	
6	Thread	2	
7	Stem O-Ring	15-32A	1
		40,50A	2
8	Ball Holder O-Ring	1	<input type="checkbox"/> EPDM <input type="checkbox"/> FKM
9	Union O-Ring	2	
10	Ball Seat O-Ring	2	
11	Handle	1	ABS
12	Ball Seat	2	PTFE

Dimension Table

Unit:mm

Size	A(B)	ød	Thread														h	øDu	LH
			L		JIS			ANSI			DIN								
			PVC	PVDF	Rc	PVC	PVDF	ødo	NPT	PVC	PVDF	ødo	Rp	PVC	PVDF	ødo			
<input type="checkbox"/> 15 (1/2)	15	97±3.0	99±3.0	1/2	18	20	30	1/2	18	20	30	1/2	18	20	30	50	49	95	
<input type="checkbox"/> 20 (3/4)	20	115±3.0	116±3.0	3/4	18	22	35	3/4	18	22	35	3/4	18	22	35	53	59	95	
<input type="checkbox"/> 25 (1)	25	128±3.0	136±3.0	1	23	24	44	1	23	24	44	1	23	24	44	66	67	123	
<input type="checkbox"/> 32 (1·1/4)	32	146±3.0	148±3.0	1·1/4	23	25	54	1·1/4	23	25	54	1·1/4	23	25	54	74	81	123	
<input type="checkbox"/> 40 (1·1/2)	40	163±3.0	169±3.0	1·1/2	25	28	65	1·1/2	25	28	65	1·1/2	25	28	65	100	98	152	
<input type="checkbox"/> 50 (2)	50	186±3.0	196±3.0	2	30	30	77	2	30	30	77	2	30	30	77	107	120	152	

Note) Thread dimension is in accordance with the following standard;
JIS:JIS B 0203,ANSI:ANSI B1.20.1 and DIN2501 PN10/PN16 (ISO7005 PN10) for DIN

Client name		Date
Handle Color	<input type="checkbox"/> Orange <input type="checkbox"/> Blue <input type="checkbox"/> Green <input type="checkbox"/> Ivory <input type="checkbox"/> White <input type="checkbox"/> Yellow	Approved by:
Flange Standard	<input type="checkbox"/> JIS <input type="checkbox"/> ANSI <input type="checkbox"/> DIN	
Oil Free	<input type="checkbox"/> YES	
ESLON TRUE UNION BALL VALVE THREAD TYPE SIZE 15 (1/2") -50 (2")		
Drawing No. BV1550NXE		
SEKISUI SEKISUI CHEMICAL CO.,LTD.		