

FACTS | FIGURES | DATA

Pressure relief valve V 185 · V 85

V 185 · V 85



## Pressure relief valve V185 · V85

DN 10 to DN 100



V185 PVDF



V185 PP



V185 PVC

### USE

The pressure relief valve V185/V85 protects systems and pipelines against overpressure and pressure peaks. The third pipe spigot integrated in the valve body allows installation in the main line. The flow-efficient and almost zero-static design of the lower body means that there is only minimum pressure loss in the valve opening.

### FUNCTION

The set spring force presses the diaphragm onto the seal seat. If the system pressure exceeds the operating pressure value, the valve opens.

### SPECIAL FEATURES

- All parts that come into contact with the medium are made of highly-resistant plastics
- The control diaphragm separates the actuating drive from the flow section
- The operating pressure is adjusted with an adjustment screw and is secured with a lock nut. The setting can also be lead sealed if required
- The shape of the housing that assists flow results in good flow values
- Control deviations are kept low by the large control surface and the spiral spring
- No auxiliary energy is required in order to operate the valve
- The valve is largely maintenance-free and can be installed in any position

## MATERIALS

Housing	Permissible operating temperature	Diaphragm
PVC-U	0 to + 60 °C	EPDM
PP	-10 to + 80 °C	EPDM/PTFE coated
PVDF	-20 to + 100 °C	

## TECHNICAL DATA

Type	Size	PN	Pressure range in bar
V185	DN 10-50	10	0.5 - 10
V85	DN 65-80	6	1-6
	DN 100	4	1-4

## DIMENSIONS IN MM (GUIDELINE VALUES)

d	DN	L	Ls	L1	L2	D	h	H
16	10	134	–	140	154	83	20	137
20	15	134	158	140	154	83	20	137
25	20	134	158	140	154	83	20	137
32	25	174	198	180	185	112	27	199
40	32	174	202	230	248	112	27	199
50	40	224	256	230	248	165	43	290
63	50	244	256	250	252	165	43	290
75	65	284	284	290	280	180	–	275
90	80	300	300	310	–	200	–	410
110	100	380	380	390	–	250	–	485

L = standard connection, Ls = IR butt fusion spigot, standard, for material PP/PVDF, L1 = with flange, L2 = with screw connection

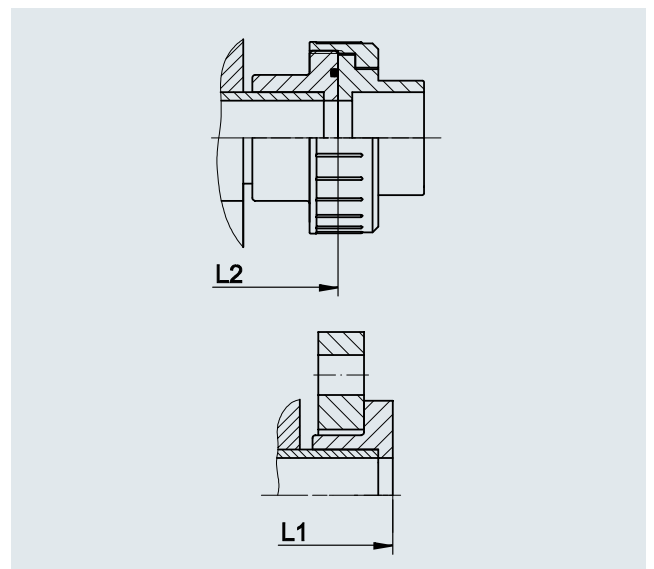
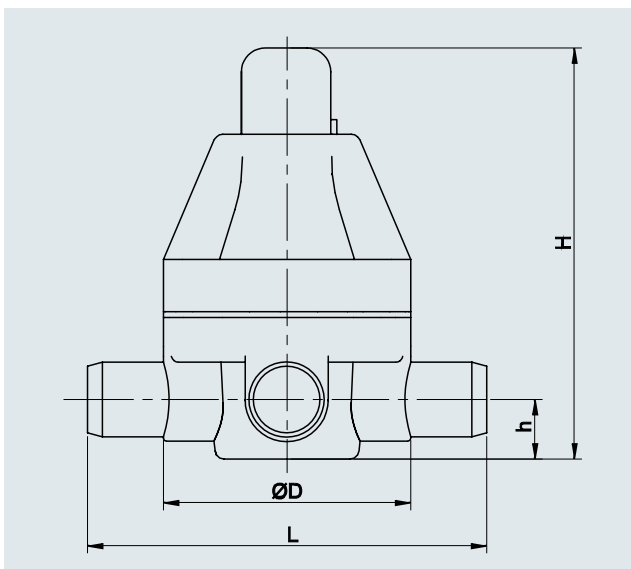

## ARTICLE NUMERBS

d	DN	Type	PVC/EPDM	PVC/PTFE	PP/EPDM IR-spigots	PP/PTFE IR-spigots	PVDF/PTFE IR-spigots
16	10	V185	17.000.120	17.000.179	17.005.444	17.005.451	17.005.458
20	15	V185	17.000.121	17.000.180	17.005.445	17.005.452	17.005.459
25	20	V185	17.000.122	17.000.181	17.005.446	17.005.453	17.005.460
32	25	V185	17.000.123	17.000.182	17.005.447	17.005.454	17.005.461
40	32	V185	17.000.124	17.000.183	17.000.448	17.005.455	17.005.462
50	40	V185	17.000.125	17.000.184	17.005.449	17.005.456	17.005.463
63	50	V185	17.000.126	17.000.185	17.005.450	17.005.457	17.005.464
75	65	V85	17.002.709	17.002.713	17.005.465	17.005.468	17.005.471
90	80	V85	17.002.717	17.002.721	17.005.466	17.005.469	–
110	100	V85	17.002.725	17.002.729	17.005.467	17.005.470	–

## INDIVIDUAL PARTS

- Pos. Designation
- 1 Lower body
  - 2 Upper body
  - 3 Diaphragm
  - 4 Compressor
  - 5 Compressor spring
  - 6 Spring plate
  - 7 Adjustment screw
  - 8 Cap
  - 9 Set of screws

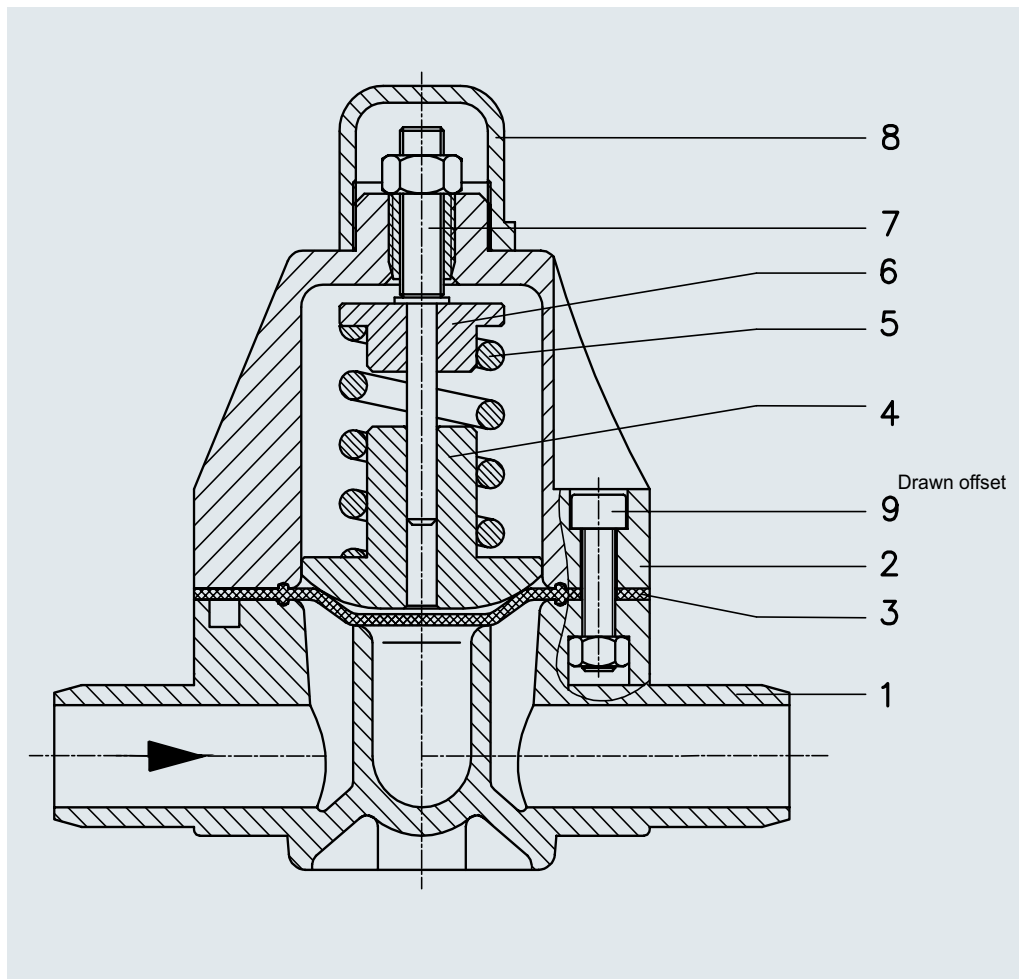

## CHARACTERISTIC GRAPHS V185

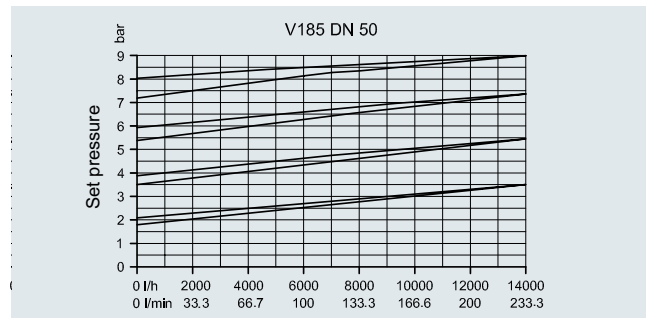
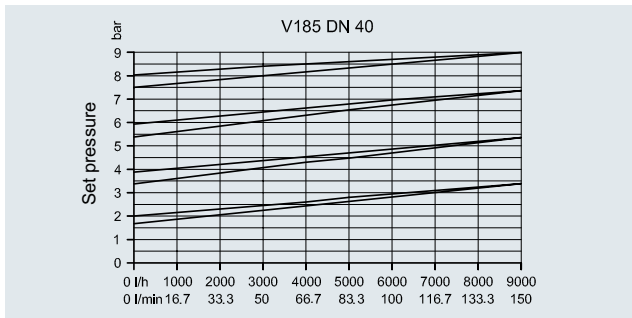
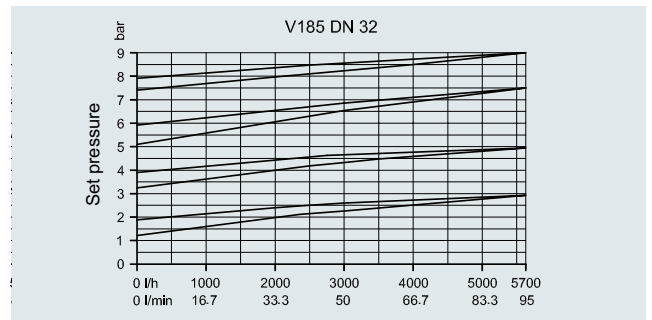
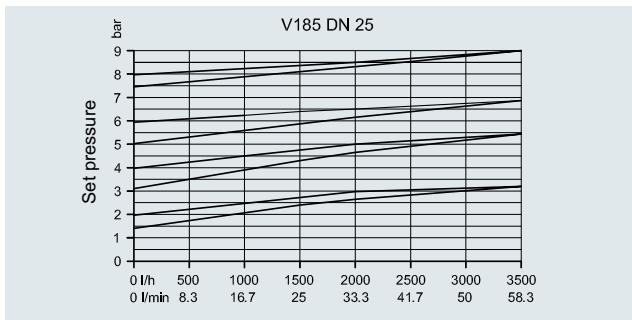
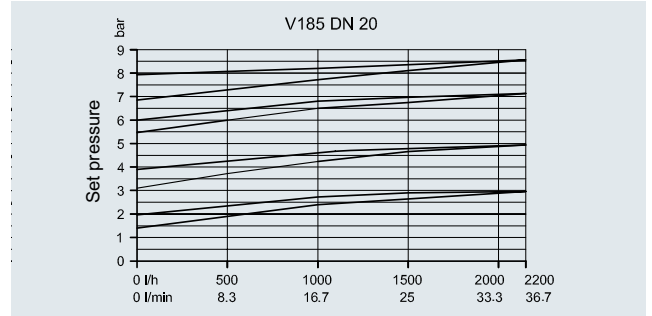
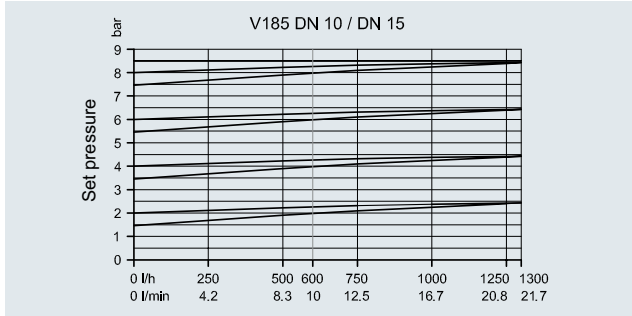

## CHARACTERISTIC GRAPHS V85

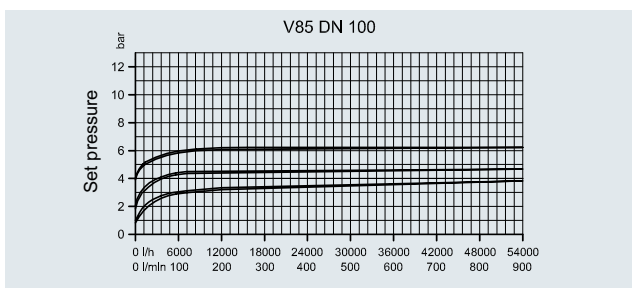
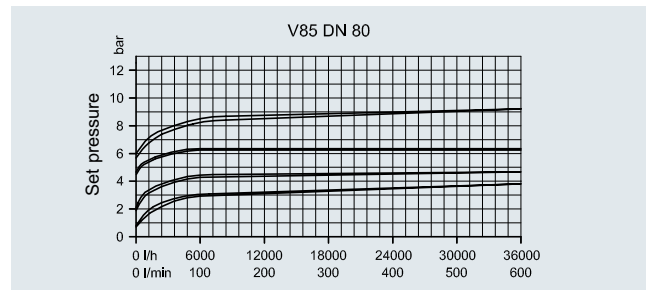
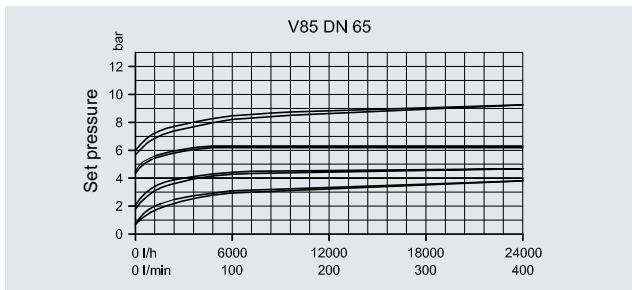

The characteristic curves on the graphs show the increase in the set pressure from 0 through to the maximum permissible flow rate. The upper and lower lines plot the course of the opening and closing pressure respectively. All characteristic curves apply to water at a temperature of 20 °C.

## SPARE PARTS SET FOR V185 / V85 PVC-U / PP / PVDF

Set consisting of:	Type	DN	PVC/EPDM Article No.	PVC/PTFE Article No.	PP/EPDM Article No.	PP/PTFE Article No.	PVDF/PTFE Article No.
Pos. 3 diaphragm	V 185	10/15/20	17.006.007	17.006.020	17.006.007	17.006.020	17.006.020
Pos. 5 compression spring	V 185	25/32	17.006.008	17.006.021	17.006.008	17.006.021	17.006.021
Pos. 7 adjustment screw	V 185	40/50	17.006.009	17.006.022	17.006.009	17.006.022	17.006.022
Pos. 10 washer							

Set consisting of:	Type	DN	PVC/EPDM Article No.	PVC/PTFE Article No.	PP/EPDM Article No.	PP/PTFE Article No.	PVDF/PTFE Article No.
Pos. 6 diaphragm	V 85	65	17.006.140	17.006.143	17.006.262	17.006.265	17.006.274
Pos. 4 spring assembly	V 85	80	17.006.141	17.006.144	17.006.263	17.006.266	–
Pos. 2 adjustment screw	V 85	100	17.006.142	17.006.145	17.006.264	17.006.267	–
Pos. 8 piston, complete							

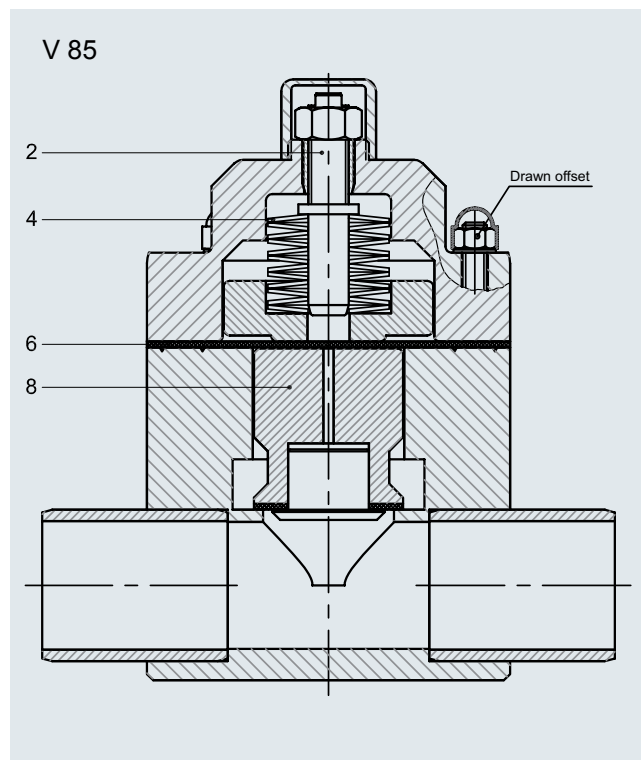
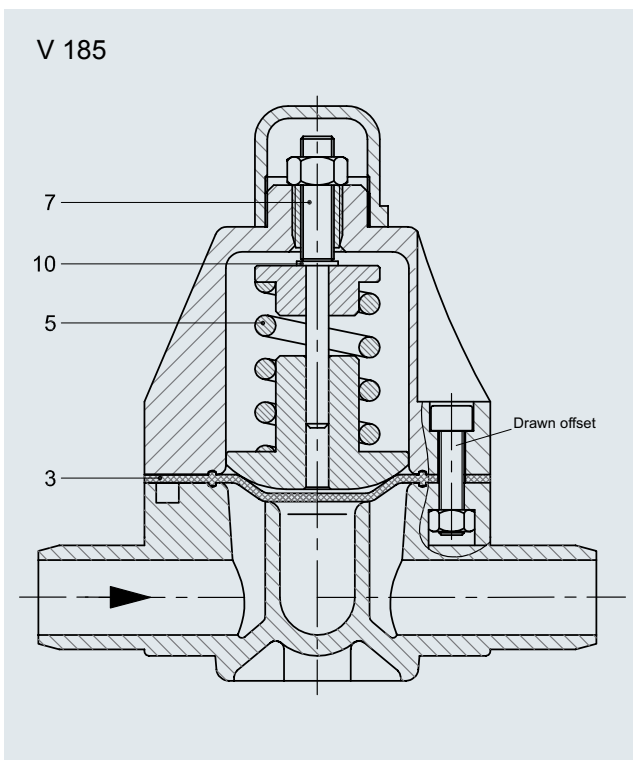

**PRESSURE RELIEF VALVE V 185**

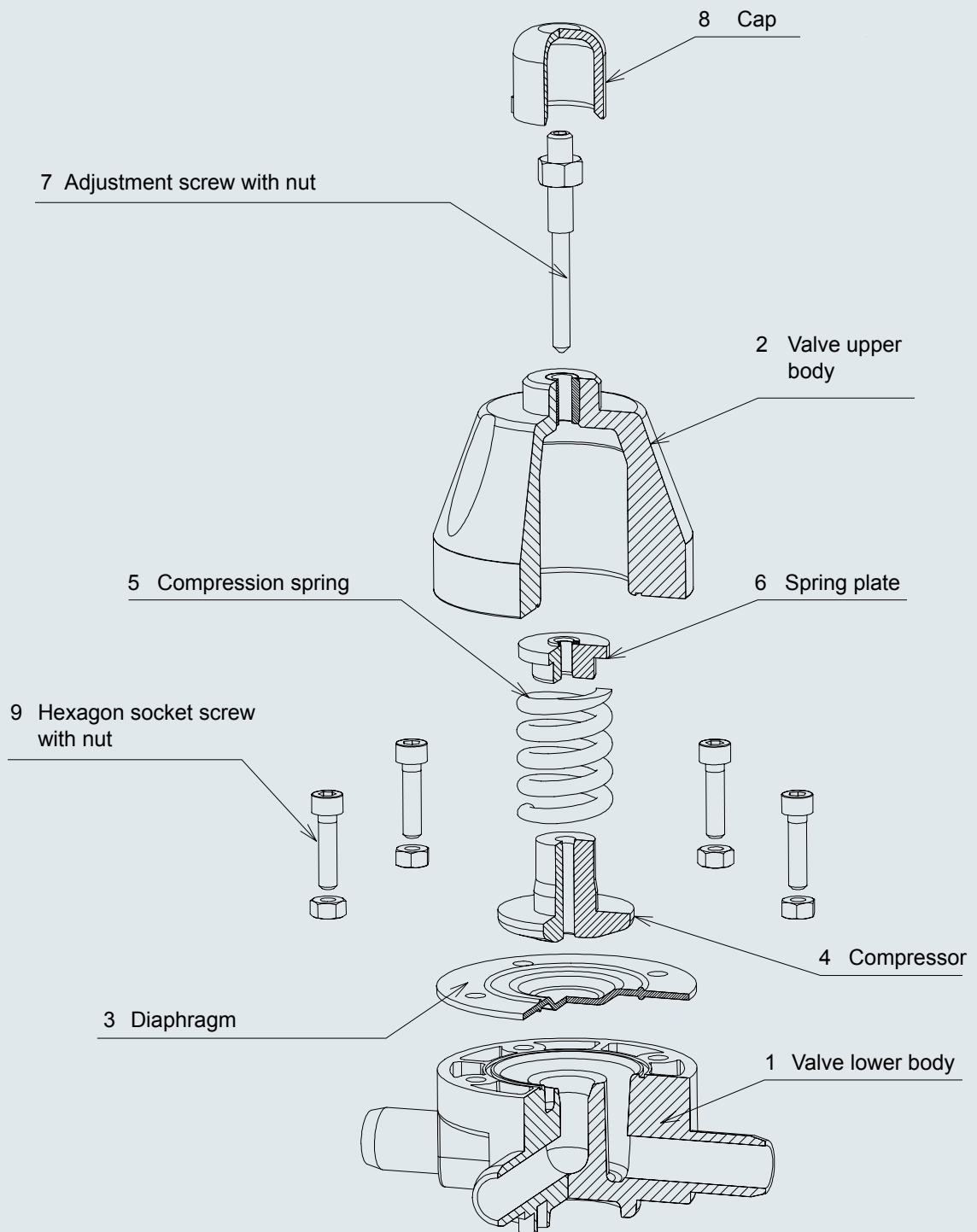

# V185 · V85

