

Metering Ball Valve Type 523 Pro



Product description

The strength of the metering Ball Valve Type 523 Pro is its ability to reliably control flow even at very low flowrates. The easy to read indicator and uniquely notched ball make precisely controlling media possible.

Applications

- Chemical process
- Life science
- Microelectronics
- Measurement and control
- Water treatment
- Shipbuilding
- Food & beverage

Benefits/features

- Fine adjustment of the dosage by special V-notch ball
- Opening angle scaled in 0° - 180° on the index plate
- Specially designed for flow control
- True union for easy installation and removal
- Lockable lever equipped as standard
- Ergonomic hand lever with integrated tool to open the union bushing
- Labeling in lever (optional)
- Integrated fixation system with mounted threaded inserts as standard
- Spacers keep the level of the piping system constant and simplify installation
- Unique Data Matrix Code for traceability

Flow media

Neutral and aggressive media with a small amount of particles/solids. The chemical resistance is dependent on the selected valve material ([see online tool ChemRes PLUS](#)).

Technical data

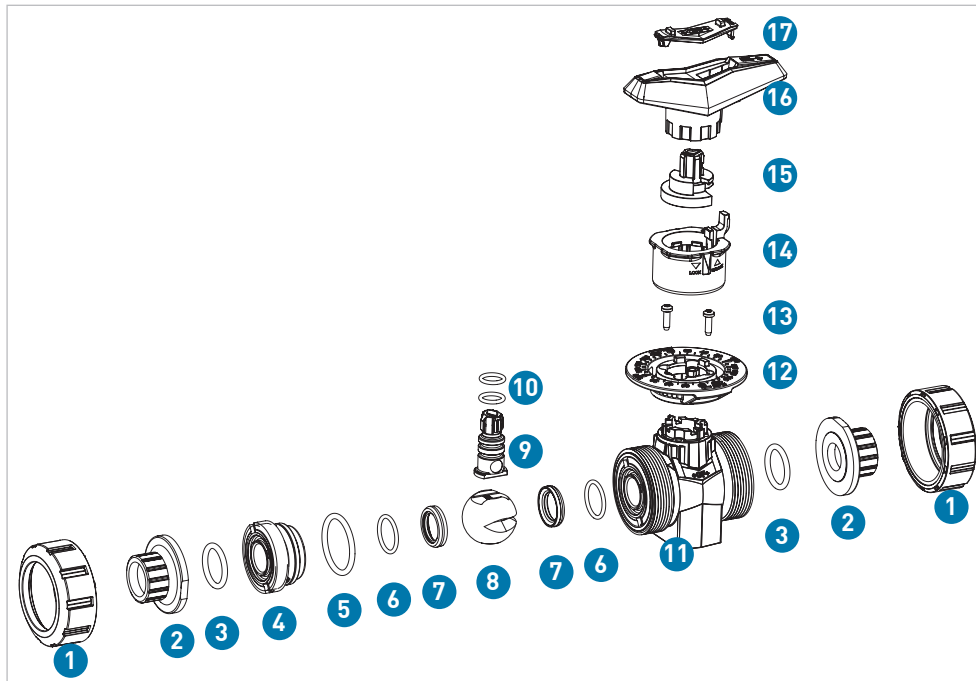

- 1 Union nut
- 2 Connecting part
- 3 Union seal
- 4 Union bush
- 5 Body seal
- 6 Backing seal
- 7 Ball seat
- 8 Ball (metering version)
- 9 Stem
- 10 Stem seals
- 11 Body
- 12 Index plate
- 13 Screws
- 14 Adapter with locking function
- 15 Position indicator
- 16 Lever (lockable)
- 17 Lever clip

Specification

Dimensions	d16/DN10 – d20/DN15, 3/8" – 1/2"	
Materials	Valve body	PVC-U, PVC-C, PP-H, PVDF
	Lever	PP-GF30
Seal materials	O-rings	EPDM, FKM
	Ball seat	PTFE
Rated pressure	PN16/10	
Actuation variants	Manually operated	
	Fusion / solvent cement sockets	ISO, ASTM, JIS, BS
	Fusion / solvent cement spigots	ISO
	Threaded socket	Rp, NPT, Rc
	Backing flange	ISO, ANSI, BS, JIS
	Butt fusion spigots	ISO
Connections		
Product standard	EN ISO 16135	
Test standard	ISO 9393-2, EN 12266-1 (leakage rate A)	
Approvals	FDA, QAP/ITP; RINA, LR	

Kv 100 values

DN (mm)	Inch (inch)	d (mm)	Kv 100 (l/min)	Cv 100 US (Gal./min)	Kv 100 (m ³ /h)
10	3/8	16	11	0.8	0.7
15	1/2	20	20	1.4	1.2

The kv values for each intermediate valve position can be determined by using the flow value characteristics and the kv 100 values.

Flow characteristics

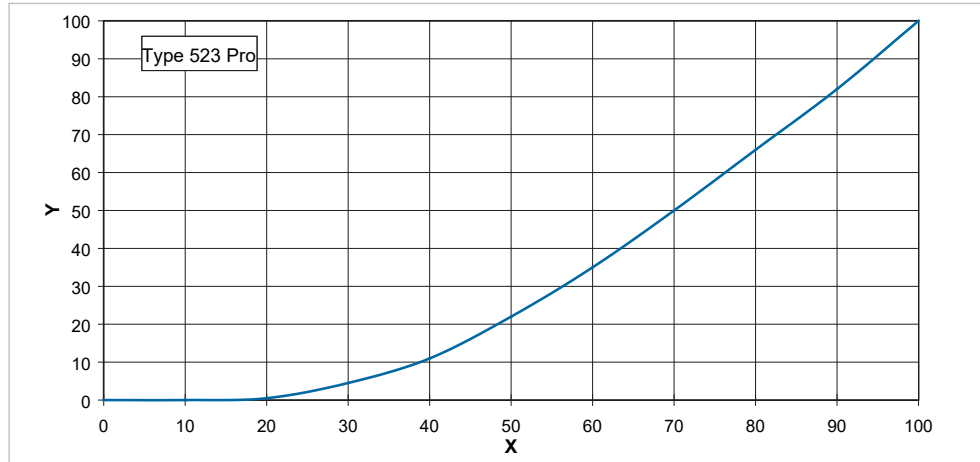

X Opening angle (%)
Y Kv, Cv value (%)

Pressure-temperature diagrams

The following pressure-temperature diagrams are based on a service life of 25 years and water or similar media.

T Temperature (°C, °F)

P Permissible pressure (bar, psi)

PVC-U

PP

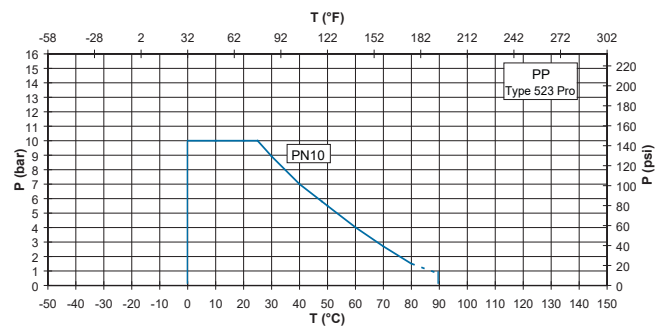
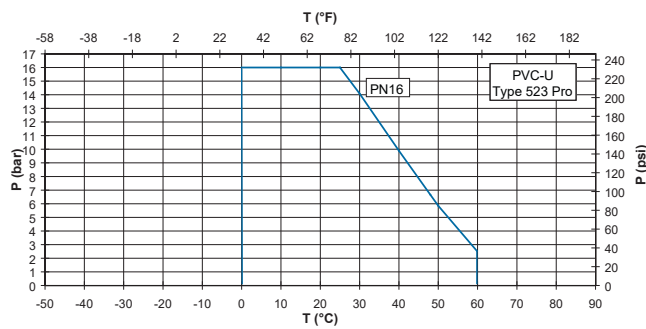

PVDF

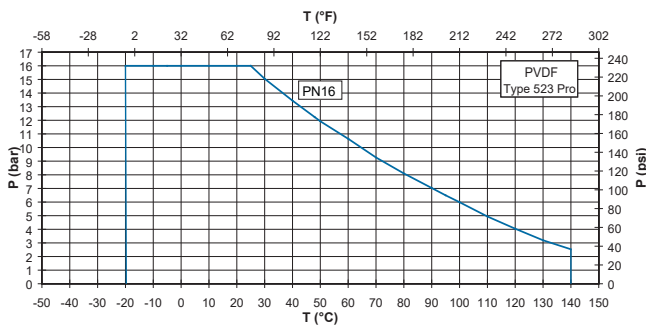

Pressure losses

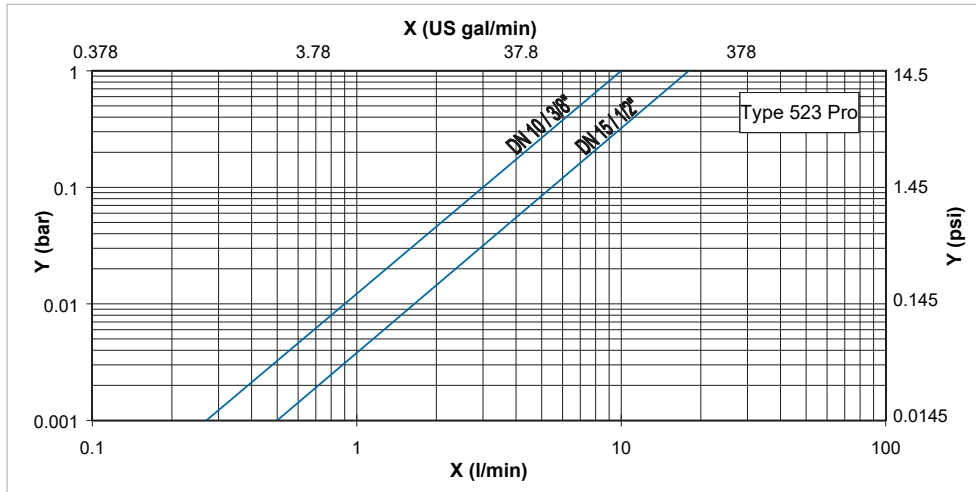

- X Flow rate (l/min, US gal/min)
- Y Pressure loss Δp (bar, psi)

Operating torque

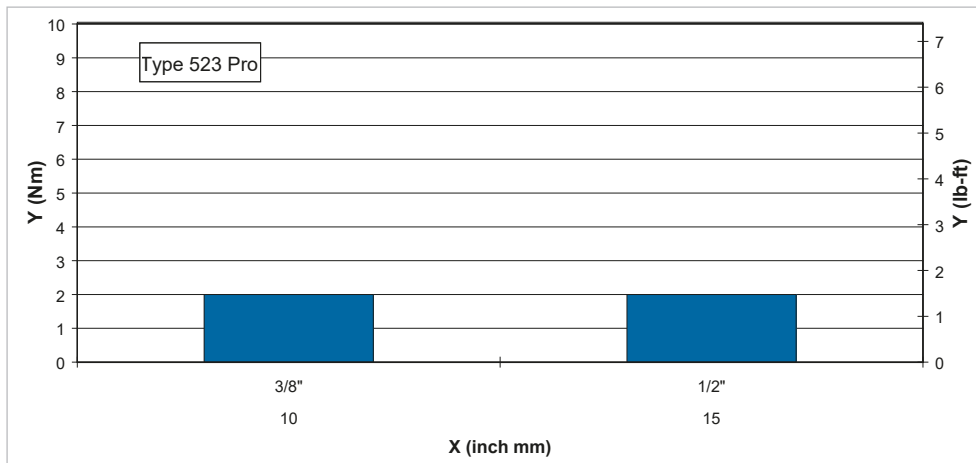

- X Nominal diameter DN (mm, inch)
 - Y Tightening torque (Nm, lb-ft)
- Average values at nominal pressure. Depending on the application (e.g. operating speed, fluid, temperature, etc.) about 2 times the operating torque should be taken for sizing actuators.

Technical basics

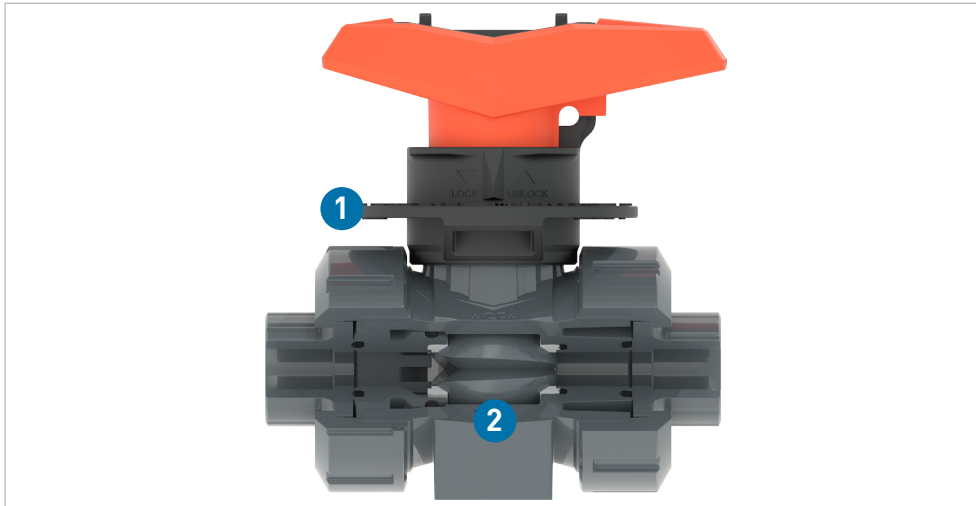

- 1 Ball with metering characteristic
- 2 Special index plate with opening angle in °

- With the backing seals, the ball has a floating position. This results in preloading and hence a constant seal. Stem, backing, housing and connection seals are made of EPDM or FKM.
- The stems with rated break point above the upper O-ring help prevent leaks to the outside in case of damage.
- The design of the hand lever serves as a tool for installing the screw-in fitting. Screw-in fittings have a reverse thread in order to avoid unintentional opening when removing the coupling nuts or the thread connections.

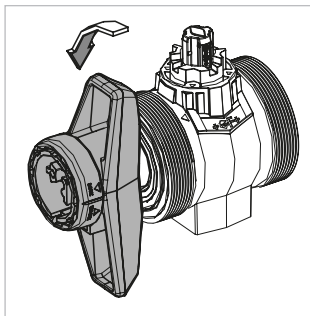

i All ball valves in DN10–15 are true union according to EN ISO 16135 for simple installation and removal from the piping system.

Reading the current flow is possible in all positions, thanks to the new circular scale, which is reflected in the center. The arrows on the scale indicate the direction of flow.

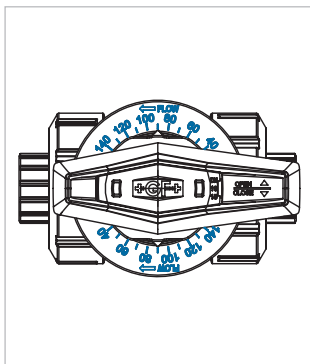

Valve handling

Installation notes

When installing the ball valve, ensure that it is always installed into the system in an opened ball position.

Selection of lubricant

All seals should be lubricated with a silicone-based grease. Using the wrong lubricants can damage the material of the ball valve or seals.

- Mineral oil-based and Vaseline (petrolatum) are not appropriate.
- For silicon-free ball valves, please consult the special manufacturer's instructions.

Maintenance notes

Ball valves require no maintenance under normal operating conditions (clear water). However, the following measures must be considered:

- Regularly check that no medium escapes to the outside.
- We recommend cycling valves 1-2 times per year that are permanently kept in the same position to check for functionality.



Installation and maintenance must be performed according to the corresponding installation instructions. The installation manual is included with the product, see also the online product catalog at www.gfps.com

Dimensions

Metering Ball Valve Type 523 Pro with solvent cement sockets

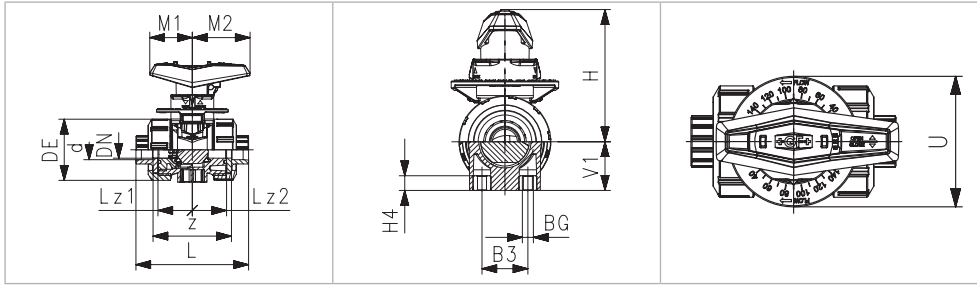

d (mm)	DN (mm)	M1 (mm)	M2 (mm)	Lz1 (mm)	Lz2 (mm)	L (mm)	V1 (mm)	H (mm)	Hmax (mm)	DE (mm)	BG (mm)	B3 (mm)	H4 (mm)	U (mm)	z (mm)
16	10	35	47	28	28	92	27	72	99	50	M6	25	12	59	64
20	15	35	47	28	28	95	27	72	99	50	M6	25	12	59	64

Metering Ball Valve Type 523 Pro with fusion sockets, metric

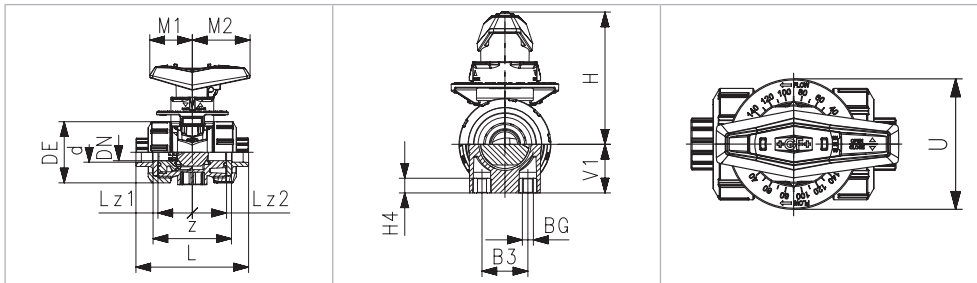

d (mm)	DN (mm)	M1 (mm)	M2 (mm)	Lz1 (mm)	Lz2 (mm)	L (mm)	V1 (mm)	H (mm)	Hmax (mm)	DE (mm)	BG (mm)	B3 (mm)	H4 (mm)	U (mm)	z (mm)
16	10	35	47	28	28	92	27	72	99	50	M6	25	12	59	67
20	15	35	47	28	28	95	27	72	99	50	M6	25	12	59	67

Metering Ball Valve Type 523 Pro with solvent cement spigots or socket fusion spigots, metric

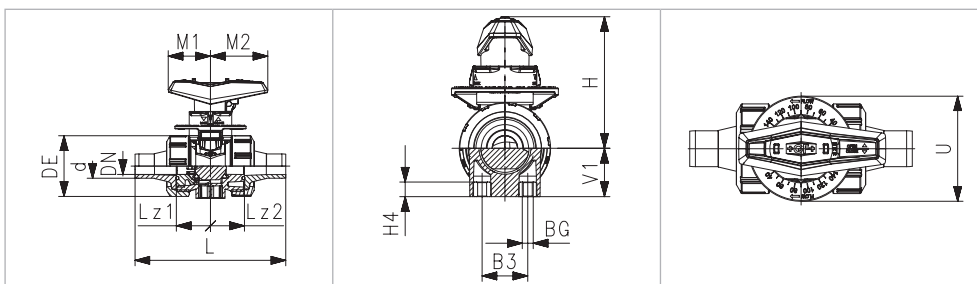

d (mm)	DN (mm)	M1 (mm)	M2 (mm)	Lz1 (mm)	Lz2 (mm)	L (mm)	V1 (mm)	H (mm)	Hmax (mm)	DE (mm)	BG (mm)	B3 (mm)	H4 (mm)	U (mm)
16	10	35	47	28	28	110	27	72	99	50	M6	25	12	59
20	15	35	47	28	28	120	27	72	99	50	M6	25	12	59

Metering Ball Valve Type 523 Pro with butt fusion spigots short, metric

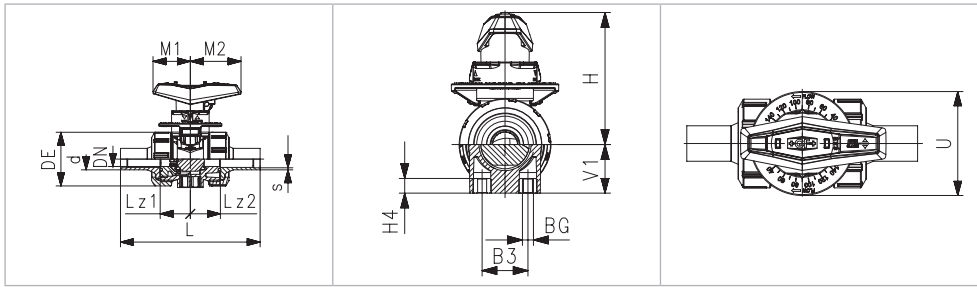

d (mm)	DN (mm)	M1 (mm)	M2 (mm)	Lz1 (mm)	Lz2 (mm)	L (mm)	V1 (mm)	H (mm)	Hmax (mm)	DE (mm)	BG (mm)	B3 (mm)	H4 (mm)	U (mm)	s (mm)
20	15	35	47	28	28	130	27	72	99	50	M6	25	12	59	1.9

Metering Ball Valve Type 523 Pro with threaded sockets, Rp

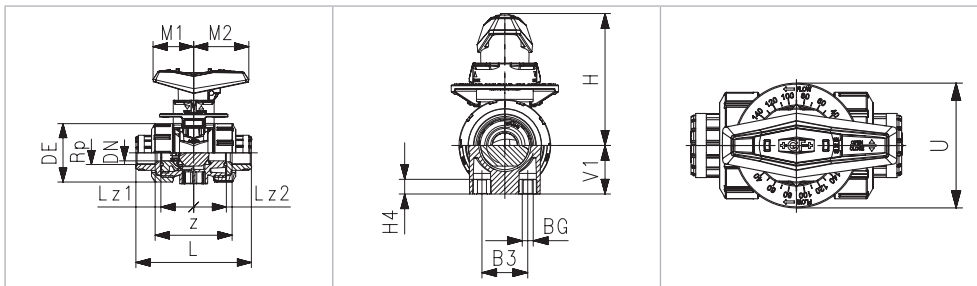

Zoll (inch)	DN (mm)	M1 (mm)	M2 (mm)	Lz1 (mm)	Lz2 (mm)	L (mm)	V1 (mm)	H (mm)	Hmax (mm)	DE (mm)	BG (mm)	B3 (mm)	H4 (mm)	U (mm)	z (mm)
3/8	10	35	47	28	28	92	27	72	99	50	M6	25	12	59	73
1/2	15	35	47	28	28	95	27	72	99	50	M6	25	12	59	71

Metering Ball Valve Type 523 Pro with threaded sockets, NPT

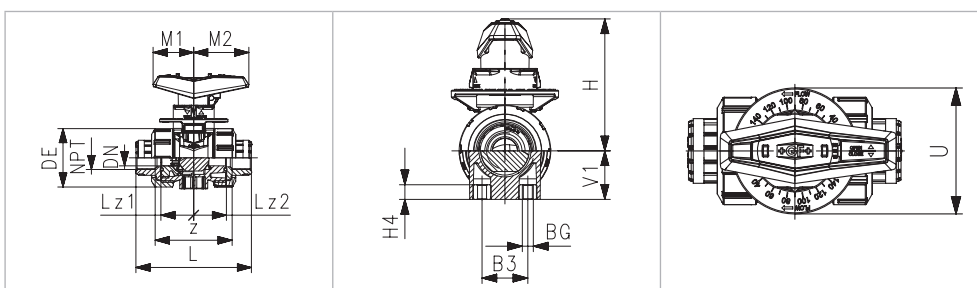

Zoll (inch)	DN (mm)	M1 (mm)	M2 (mm)	Lz1 (mm)	Lz2 (mm)	L (mm)	V1 (mm)	H (mm)	Hmax (mm)	DE (mm)	BG (mm)	B3 (mm)	H4 (mm)	U (mm)	z (mm)
3/8	10	35	47	28	28	92	27	72	99	50	M6	25	12	59	73
1/2	15	35	47	28	28	95	27	72	99	50	M6	25	12	59	71

Angetriebene Versionen

Metrische Kugelhähne vom Typ 523 Pro sind als elektrisch und pneumatisch angetriebene Versionen erhältlich.

Für Abmessungen siehe Kugelhahn Typ 546 Pro.



For further information on accessories, refer to the online product catalogue at www.gfps.com

- Mobile apps and online tools to support configuration and calculation at www.gfps.com/tools



The information and technical data (altogether "Data") herein are not binding, unless explicitly confirmed in writing. The Data neither constitutes any expressed, implied or warranted characteristics, nor guaranteed properties or a guaranteed durability. All Data is subject to modification. The General Terms and Conditions of Sale of Georg Fischer Piping Systems apply.

10/2023-A

© Georg Fischer Piping Systems Ltd, 8201 Schaffhausen/Switzerland

Tel. +41 52 631 11 11 • www.gfps.com • E-Mail: info.ps@georgfischer.com